

COMPUTER ASSISTED INTELLIGENT HIGHWAY SAFETY & ALERT SYSTEM IN RELATION TO INDIAN SCENARIO USING LABVIEW

S. SHARMA

*Gujarat Technological University/EC Department, Ahmedabad, India
Email: sharma.f@gmail.com*

D. SHAH AND R. BHAVSAR

*Gujarat Technological University/ EC Department, Ahmedabad, India
Email: {djshah99, rishikesh.147}@gmail.com*

ABSTRACT: Intelligent highway safety systems are very helpful as they help us in reducing the number of accidents that are happening on the road between the vehicle and other obstacles on the road. By intelligent highway safety system, we mean automatic lane detection and object detection (vehicle detection, pedestrian detection and animal detection) systems which assist the driver by identifying the potential threat on the road and also give the alert signal to the driver for preventing the collision of the vehicle with the other obstacles on the road. Lot of work has already been done in automatic lane detection, vehicle detection and pedestrian detection but still researches are going on in automatic animal detection system which can help in reducing the number of collisions that are happening between vehicle and the animals on the road. In this paper first we will briefly explain the necessity of automatic animal detection system, then the brief survey of other methods which have been used in the past for the animal detection followed by our proposed method based on image processing techniques and Vision Assistant and LabVIEW software of NI for automatic animal detection in relation to Indian scenario. The proposed technique is applied to different videos of cow and dog which are mostly found on Indian roads. The system correctly identifies the animal in the video and also alerts the driver once the animal is detected in the video. An overall efficiency of almost 90% is achieved for animal detection.

KEYWORDS: animal detection system, intelligent highway safety, image processing, labview, national instrument, vision assistant.

INTRODUCTION

Modern Vehicle design is driven by the need for increased comfort, safety and security. This resulted in intelligent vehicles which made them to rely more on the modern technology. Of all the three needs desired by the driver of the vehicle and due to increased number of accidents occurring on the roads, safety of an automobile is given the highest priority. Once a report brought by the media stated that the damaged property due to accident and other costs may equal 3 % of the world's gross domestic product [1]. India has a high frequency of severe road accidents. The road accidents are increasing due to increase in number of vehicles on the road day by day and also due to the absence of any intelligent highway safety and alert system. According to data given in [2], the number of persons who lost their lives in India due to road accident was almost 0.11 million deaths in 2006, which was almost 10% of the total road accident deaths in the world.

NECESSITY OF DRIVER ASSISTANCE SYSTEM

Because human safety is the highest priority in a vehicle, different manufactures have been active in developing active and passive safety systems which could totally mitigate accidents in a best case scenario. An important aspect of developing active and passive safety systems is the capability of the vehicle to perceive and interpret its environment, recognize dangerous situations and support the driver and his driving maneuvers in the best possible way. A short distraction while driving the car or automobile has enormous consequences. A statistical analysis of the causes of accidents outside urban areas in India in the year 2006 as shown in Fig. 1 indicates that more than one-third of all accidents can be traced back to a lane change or unintentionally leaving a lane and remaining two-third combination of different situations like rear collision, obstacle collision, pedestrian intersection, animal collision and others [3].

Lot of work has already been done in automatic lane detection, vehicle detection and pedestrian detection but still researches are going on in automatic animal detection system. Again the animal detection algorithm varies country to country and each country has different range of animals which are in majority and comes on the road more often than others. As for example in Saudi Arabia, there are plenty of camels which come on the road and creates problem for the driver [4]. In Australia, kangaroos are the major animals found on the road. Talking about Indian roads, there are two types of animals namely cow and dog which are found more often than others on the roads.

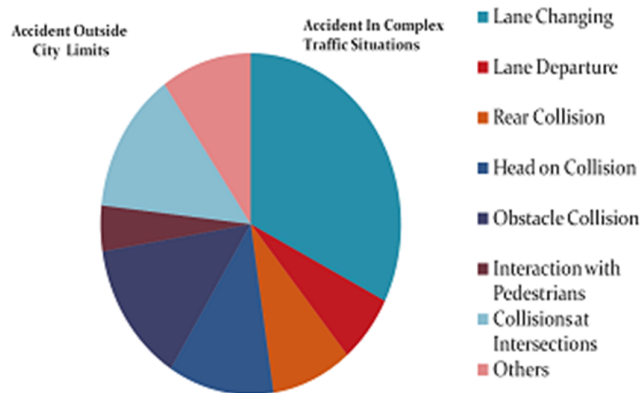

Figure 1. Causes of road accident in India

LITERATURE SURVEY

Various techniques for detection and tracking of animals have been used in the past by many researchers. Work done in [5] showed that human beings can take a decision whether an animal is there or no in the scene as fast as 150ms. The problem with this method is human eyes need some rest and that's why this method is not that effective. Researchers in [6] used threshold segmentation approach for getting the targeted animal's details from background. Work done in [7] showed that it is difficult to decide the threshold value as the background changes every so often. Researchers in [8] tried to discover out whether the animal's presence in the scene (image)

affects the power spectrum of the image or not. Work done in [9] showed that this method of detecting the animal is not appropriate if a user wants fast result as this method involves lot of time in processing of image.

In Saudi Arabia, the number of collisions between camel and vehicle were estimated more than hundred each year. To prevent this collision, an intelligent Camel Vehicle Accident Avoidance System (CVAAS) was designed using GPS (global positioning system) [4]. For finding the correct position of fishes in the sea, researchers in [10] designed a technique using LIDAR (light detection and ranging). Using micro-Doppler technique, researchers in [11] did some work for preventing risky animal intrusions in the housing area. Researchers in [12] used haar function (feature) for detecting animal faces for observing the behaviour of animals.

BRIEF OVERVIEW OF LABVIEW AND VISION ASSISTANT SOFTWARE

LabVIEW Software

LabVIEW stands for Laboratory Virtual Instrument Engineering Workbench. It is a graphical language from NI used for acquiring, testing and measuring, automating the process, storing as well as doing some analysis on the data [13]. It consists of two parts:

Front Panel: Front Panel window is the interface to the VI (Virtual Instrument) code, containing visual waveform charts, knobs, switches, indicators, tables and all other virtual things needed for easy interaction with the project designed. Fig. 2 contains front panel of the simple addition and subtraction than multiplication program.

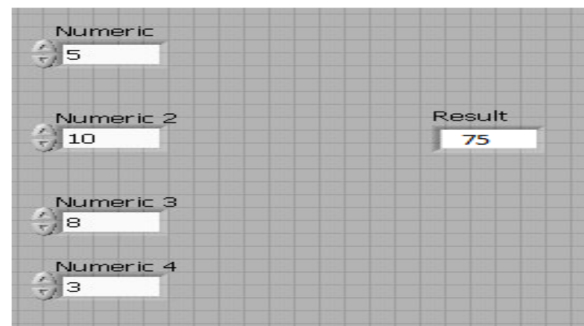

Figure 2. Front panel of labview

Block Diagram: Block Diagram window contains graphical program code such as icons of different functionalities, wires, loops, sequences, structures, conditions, data and all the things needed for programming graphically. If LabVIEW does not contains the graphical code required for us, then it can be created by our self easily by graphical codes provided by LabVIEW itself or even by other programming languages, without actually using that particular software. Fig. 3 shows the block diagram of LabVIEW.

Vision Assistant Toolbox

National Instruments Vision Assistant software is a tool for prototyping and testing image processing applications [14]. With this tool one can acquire images from the selected camera,

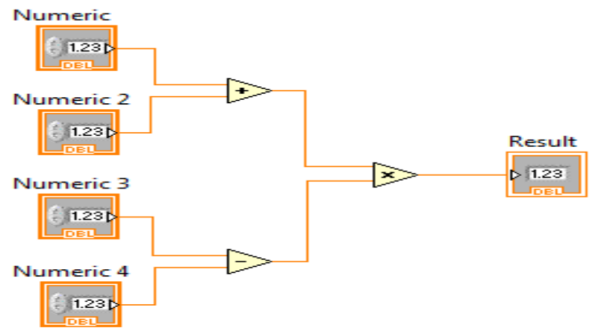

Figure 3. Corresponding block diagram of labview

selected IEEE camera 1394, Gigabit Ethernet, USB, or IP camera and image acquisition boards. One can process the images by applying all the image processing techniques such as histogram, line intensity, color classification, segmentation, color pattern matching, object tracking, morphological and binary Operations, edge detection and many others. Below are some of the snapshots (Fig. 4, Fig. 5 and Fig. 6) of vision assistant module for reference.

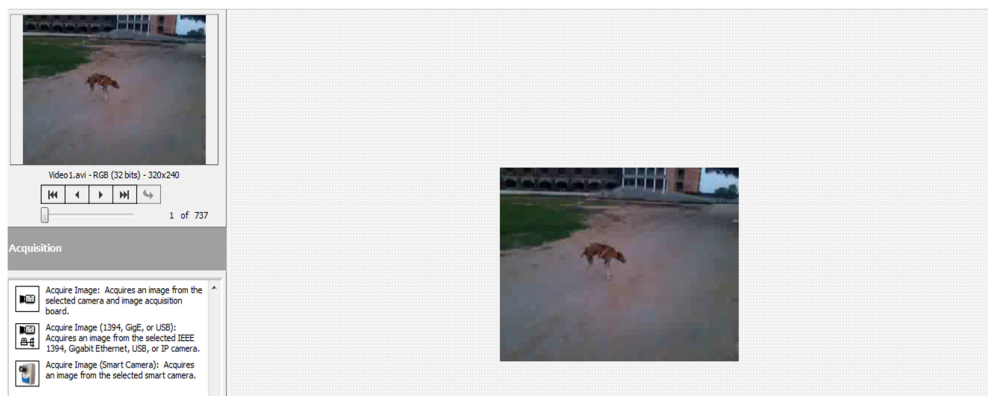

Figure 4. Acquiring images using vision assistant toolbox

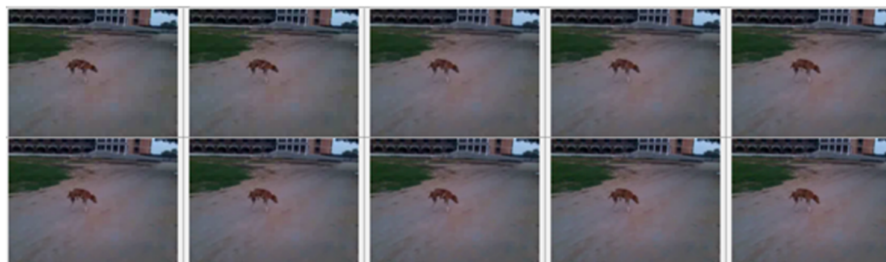

Figure 5. Browsing images using vision assistant toolbox



Figure 6. Processing images using vision assistant toolbox

BRIEF ABOUT FRAME DIFFERENCING AND TEMPLATE MATCHING

Frame Differencing

Frame differencing is a technique in image processing which takes the difference between the two frames of the video for finding the moving objects in the video [15]. It uses the concept of difference in pixel intensity for finding the moving object.

Template Matching

Template matching is a technique in which there are two images, source (target) image and template image and matches are found between them on the basis of intensity values of the pixels [16]. The highest value gives the highest matching area. See Fig. 7 for reference.

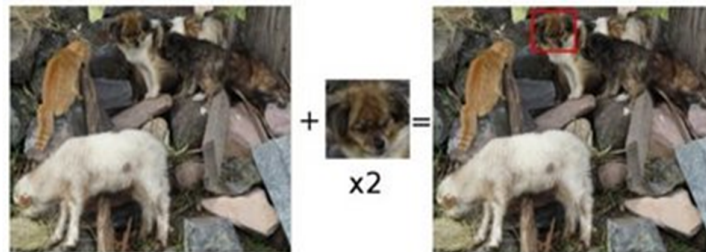

Figure 7. Example of template matching

PROPOSED METHOD

As shown above in Fig. 8, video is taken from a forward facing camera in which moving animal is there apart from other stationary and non-stationary objects. This video is stored in the computer and given to national instruments vision assistant software which converts video into different frames. Using frame differencing method, the moving object is detected and separated from different frames. After detection and separation of moving object is done, we are using color pattern matching and template matching technique for animal identification. Matching based on

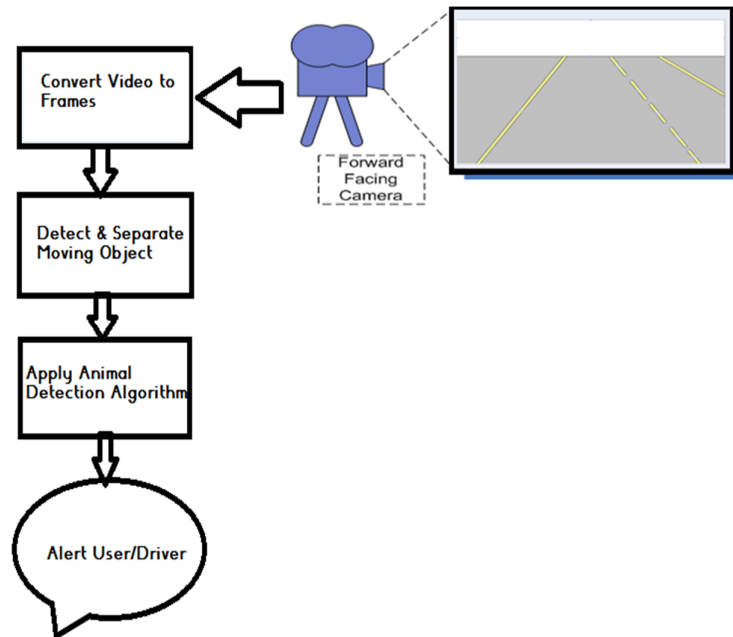

Figure 8. Block diagram of the proposed method

pattern matching uses a mixture of color location and gray scale pattern matching to search for the template [14]. When using color pattern matching for searching a template, the software uses the color information in the template to look for occurrences of the template in the image. The software then applies gray scale pattern matching in a region around each of these occurrences to find the exact position of the template in the image. All the image processing techniques are implemented in vision assistant software. Once the animal gets detected in the video, next step is to alert the driver using a buzzer or alert button which is implemented in LabVIEW software.

IMPLEMENTATION OF THE SYSTEM

After applying frame differencing method for finding and separating moving object from the frame, next for extracting animal feature from the frame first we have to create animal database. As we are doing animal detection in relation to indian scenario and as none of the researches have been done till today in this area as per our knowledge, we didn't get much data from other sources. Though a good source for the animal images is KTH dataset [17] and NEC dataset [18] which consists of more than 7000 animal images taken at various poses. Some more animal images have been taken by ourselves for creating a healthy database. Then we created two folders. One folder has the target video (different frames of video) images and the other folder has the template images. Next we are comparing the target video (different frames) with stored animal image (template) database. Some of the frames of target video (Fig. 9) and some of the template images (Fig. 10) are shown below.

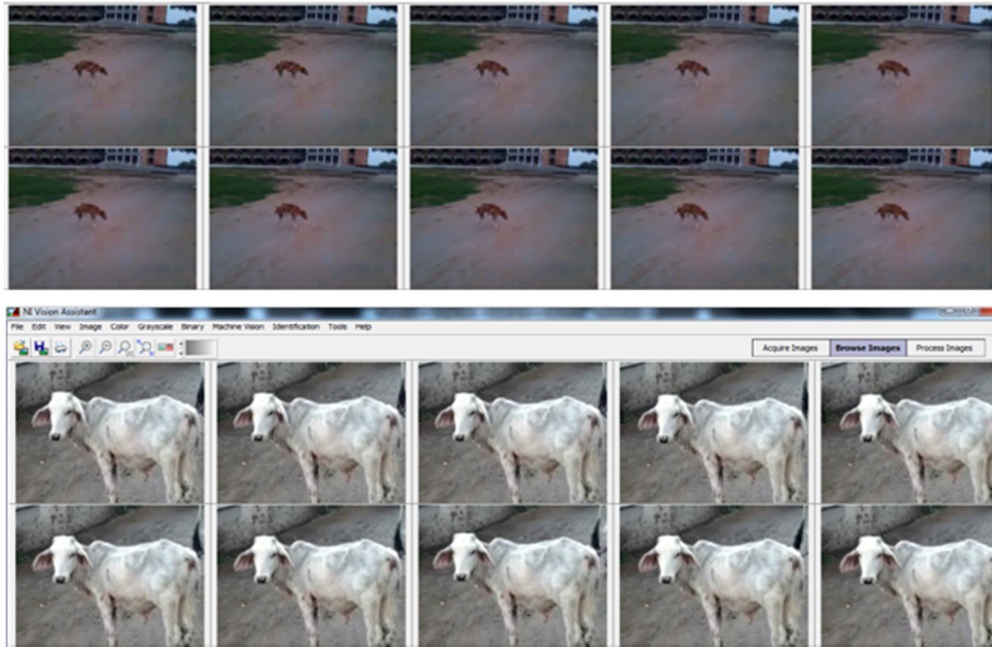

Figure 9. Target database (some frames of the continuous video)



Figure 10. Some images of template database

TESTING THE SYSTEM

As shown above in Fig. 11 and Fig. 12, once the entire necessary path is given in the front panel by the user and the start button is pressed, it will turn into green color and the video will be displayed on the front panel. If there is no animal in the video, then alert button will not glow i.e.

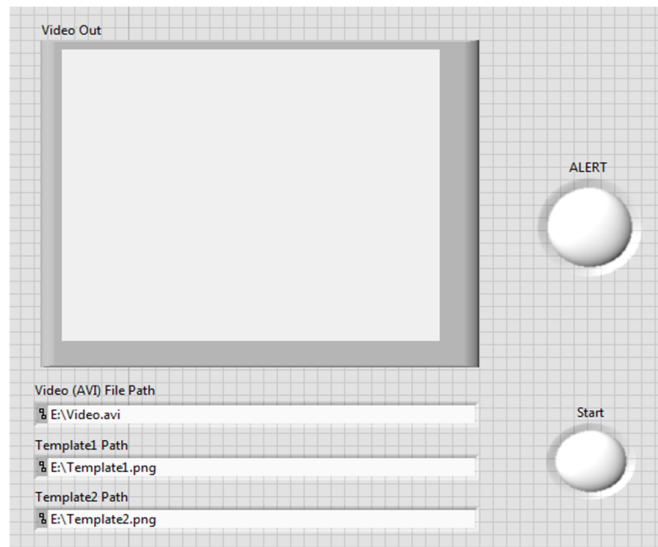

Figure 11. Front panel of automatic animal detection and alert system

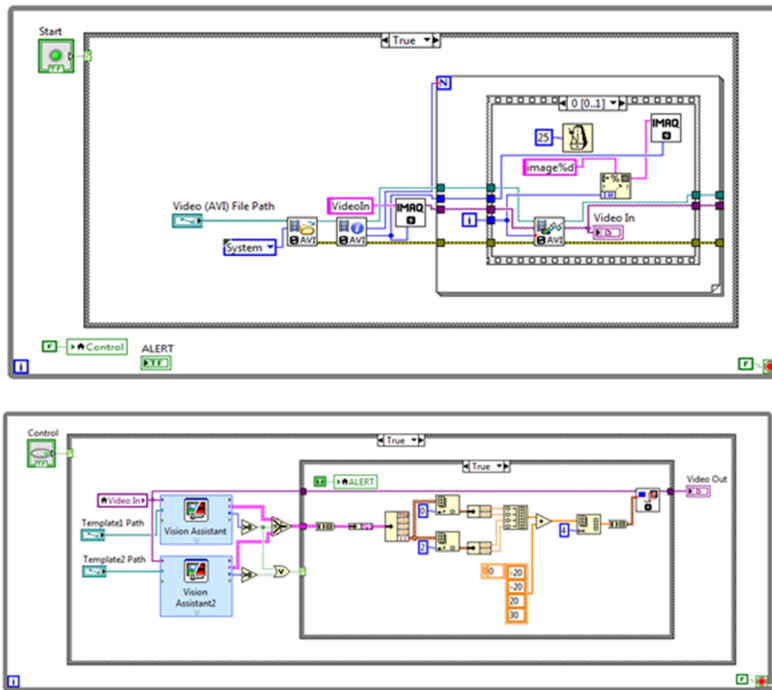

Figure 12. Corresponding block diagram of automatic animal detection and alert system

its color won't change into red. If there is any animal present in the scene (video), then that animal will have a bounding box (rectangle) on it as well as the system will alert the driver (user) with an alert button i.e. the status of the alert button will turn into red color.

As shown in the Fig. 13, when the user presses the start button, video gets displayed on the front panel. As there is no animal in the video, the alert button doesn't glow.

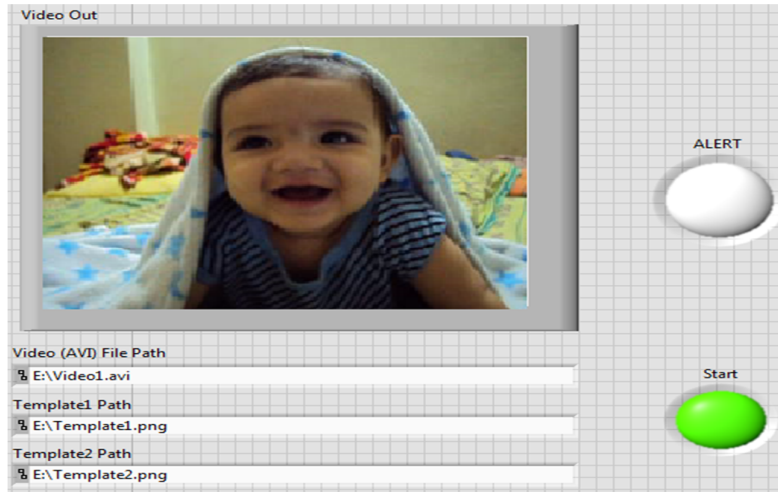

Figure 13. Alert button off as no animal in the video

In the next Fig. 14, when the user presses the start button, video gets displayed on the front panel. As there is an animal in the video, a bounding box (rectangle) will appear on the animal as well as the system alerts the driver (user) with an alert button i.e. the status of the alert button turns into red color.

Please note that the system is capable of taking more than two template images and we have tested videos with different template images also. There are some minor modifications in the code for taking more than two template images (we need to add more vision assistant modules in block diagram).

RESULTS AND DISCUSSION

One of the important parameter for checking how accurately the system detects the animal and gives the alert signal to the driver is its efficiency [19]. Efficiency of the system is given by

$$Efficiency = (TN + TP) / (TN + TP + FN + FP) \quad (1)$$

Where

TN is the true negative, TP is the true positive, FN is the false negative, and FP is the false positive. The true positives (TP) and true negatives (TN) are true parameters of classifications. False Positive (FP) shows that there is a rectangle (box) on the frame even if there is no animal present therein. In our detection system, we took 230 frames out of which 20 frames are showing

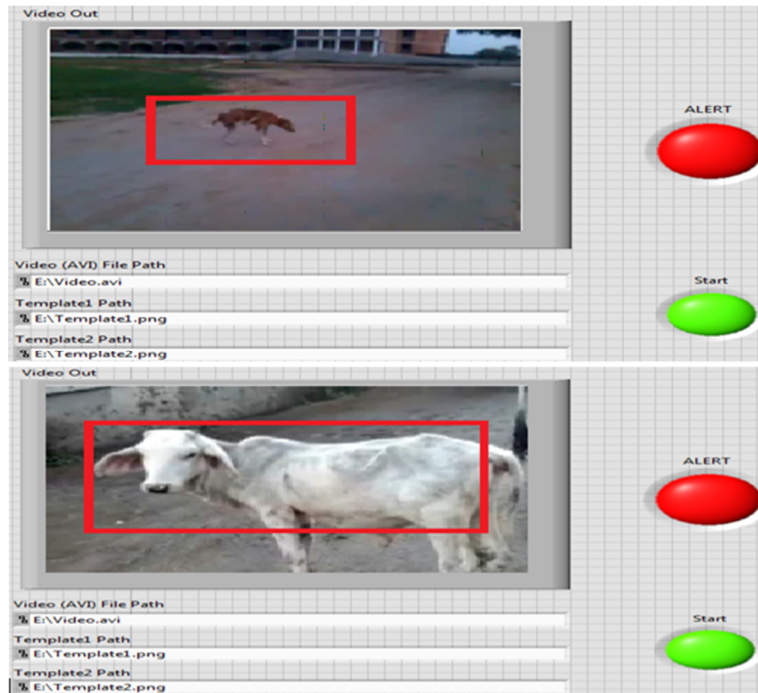

Figure 14. Alert button starts glowing as animal is detected in the video

box even though there is no animal. So, false positive is 20 whereas true negative turns out to be 210. False Negative (FN) shows that there is no box on the frame (animal) even though animal is there in the frame. So out of 230 frames, 26 frames are not showing rectangle (box) even though animal is there in the frame. So false negative is 26 whereas true positive turns out to be 204.

Fig. 15 and Fig. 16 shows the false positive and false negative scenario.

By putting values of all the parameters in (1), we get the efficiency of the system to be almost 90%.

CONCLUSION

Intelligent highway safety systems are very helpful as they helps us in reducing the number of accidents that are happening on the road between the vehicle and other obstacles on the road. Again in particular automatic animal detection and driver alert systems can help us in reducing the number of accidents between vehicle and animals on the road. Collision between vehicle and animal affects wildlife and human safety. In this paper first we briefly explained the necessity of such Intelligent highway safety systems in particular animal detection system and then the pros and cons of different methods used in the past by different researchers for detection of animal. Next we explained our method based on image processing techniques and vision assistant and labview software for animal detection and alerting the driver. We implemented and tested our

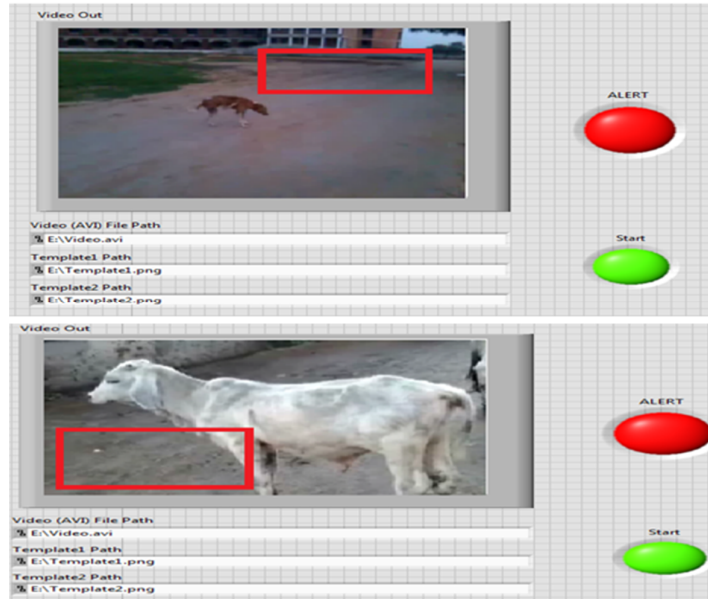

Figure 15. False positive scenario

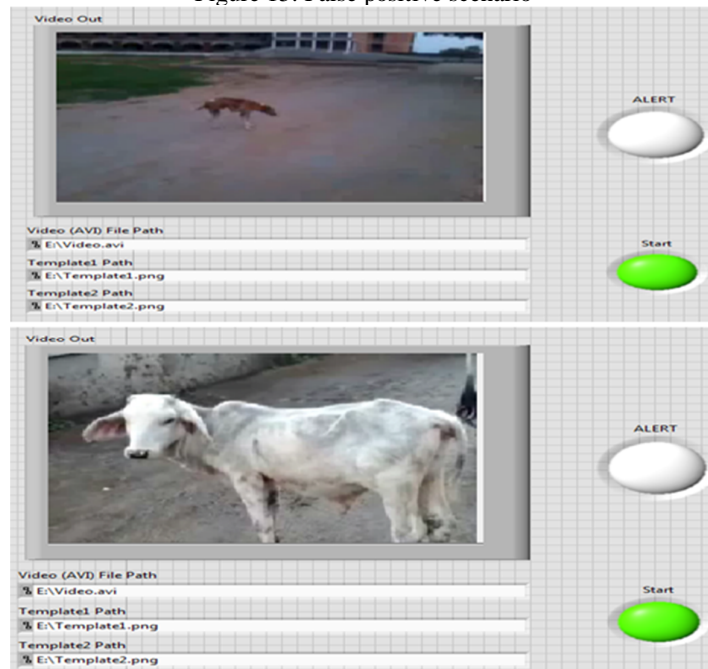

Figure 16. False negative scenario

method on different videos of cows and dogs. The success rate of identifying the animal and alerting the driver came close to 90% with our method.

There are certain points which should be taken in future development like distance of animal from the vehicle in which camera is mounted, speed test to verify how early the system detects the animal and generates an alarm to notify the driver so that the driver can apply brakes or take other necessary action. Again the work done in this paper is only for day time. No effort has been taken in detecting the animal during night time which is still an important and challenging area to work on. So this area of automatic animal detection and alerting the driver will have many things to look upon in future.

ACKNOWLEDGMENT

We would like to thank Kishor and Bhavesh for collecting the image and the video material.

REFERENCES

- M. Peden, R. Scurfield, D. Sleet, D. Mohan, AA. Hyder and E. Jarawan, "World report on road traffic injury prevention", *Geneva, World Health Organization*, 2004.
- Accidental deaths and suicides in India-2006, National Crime Records Bureau, Ministry of Home Affairs, Government of India: <http://www.ncbi.nlm.nih.gov/pmc/articles/PMC2940192/#CIT5>.
- Research Wing of the Ministry of Road Transport and Highways, New Delhi, Government of India: <http://morth.nic.in/writereaddata/mainlinkFile/File835.pdf>.
- M.S. Zahrani, Khaled Ragab and Asrar Ul Haque, "Design of GPS based system to avoid camel-vehicle collisions: A Review," *Asian Journal of Applied Sciences*, vol 4, pp.362 – 377, May 2011.
- M. F. Thorpe, A. Delorme, and S. T. C. Marlot, "A limit to the speed processing in ultra-rapid visual categorization of novel natural scene," *Cognitive Neuroscience*, pp. 171-180, 2003.
- C. Peijiang, "Moving object detection based on background extraction," *Computer Network and Multimedia Technology (CNMT)*, 2009.
- J. C. Nascimento and J. S. Marques, "Performance evaluation of object detection algorithms for video surveillance," *IEEE Transactions on Multimedia*, vol. 8, pp. 761-774, 2006.
- H.Ragheb, S. Velastin, P. Remagnino and T. Ellis, "Human Action Recognition using Robust Power Spectrum Features ", *15th International Conference on Image Processing, (ICIPO'08)* , p.753-756, San Diego, CA, October 2008
- F. A. Wichmann, J. Drewes, P. Rosas, and K. R. Gegenfurtner, "Animal detection in natural scenes: Critical review revisited," *Journal of Vision*, vol. 10, no. 4, pp. 1-27, 2010.
- V. Mitra, C. Jiu Wang, and G. Edwards, "Neural network for LIDAR detection of fish," in *Neural Networks Proceedings of the International Joint Conference*, vol. 2, pp. 1001-1006, 2003.
- D. Tahmouh and J. Silvious, "Modeled gait variations in human micro-Doppler," *2010 11th International Radar Symposium (IRS)*, pp. 1-4, 2010.
- T. Burghardt and J. Calic, "Real-time face detection and tracking of animals," *8th Seminar on Neural Network Applications in Electrical Engineering*, pp. 27-32, 2006.
- LabVIEW User Manual, National Instruments, 2013
- NI Vision Assistant Tutorial: www.ni.com/pdf/manuals/371007b.pdf
- RupaliS.Rakibe, BharatiD.Patil, *Background Subtraction Algorithm Based Human Motion Detection*, International Journal of Scientific and Research Publications, vol. 3, Issue 5, pp. 14, May2009.

- M. Sonka, V. Hlavac, and R. Boyle, "Image Processing, Analysis, and Machine Vision", Third Edition, Thompson Learning, Toronto, Ontario, Canada, 2008.
- KTH Animal Dataset: <http://www.kth.se>
- Hossein Mobahi, Ronan Collobert and Jason Weston, "Deep Learning from Temporal Coherence in Video", *Proceedings of the 26th Annual International Conference on Machine Learning (ICML'09)*, p.737- 744, June 14-18, 2009, Montreal, Quebec, Canada, June 2009.
- S. Sharma, D. Shah, R. Bhavsar, B. Jaiswal and K. Bamniya "Automated Detection of Animals in Context to Indian Scenario", *2014 Fifth International Conference on Intelligent Systems, Modelling and Simulation, Malaysia*, pp. 334-338, January 2014.